

# CIRCULAR 26482 AIRSIDE CRIMP PLUG TO WIRE ASSEMBLY

FIG 1

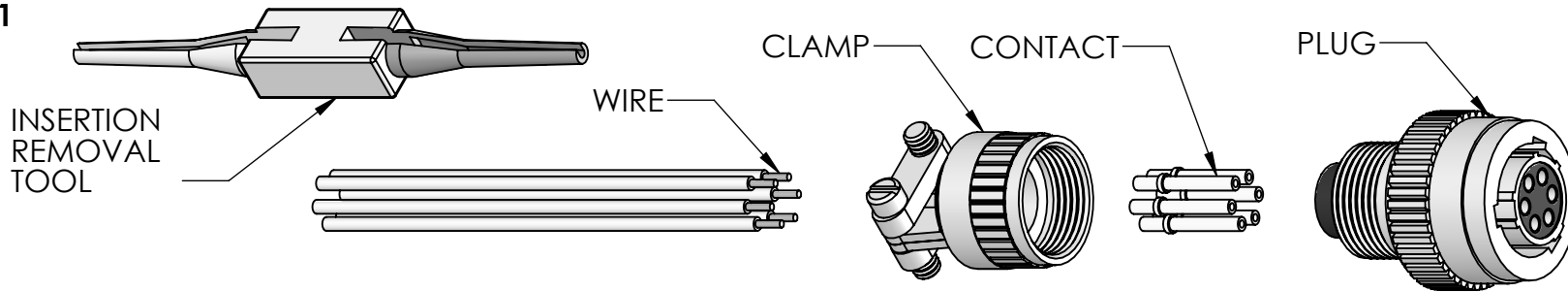

FIG 2

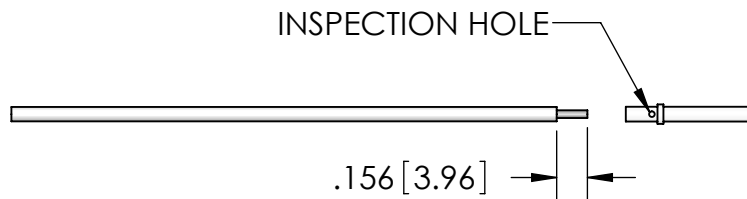
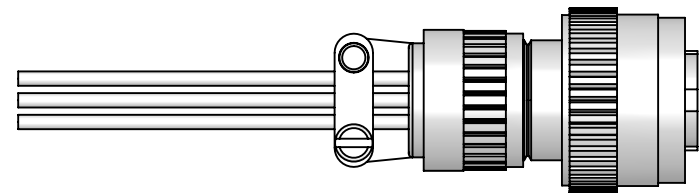

FIG 4



TIGHTEN CLAMP ONTO PLUG.

\*CONTACTS ACCEPT 20-24 AWG WIRE SIZE FOR CRIMP. STRIP END OF WIRE TO DIMENSION SHOWN. INSERT WIRE FULLY INTO CONTACT, WIRE SHOULD BE VISIBLE IN INSPECTION HOLE. CRIMP WIRE TO CONTACT USING CRIMP TOOL SST P/N FP44440 AND LOCATOR SST P/N FP44441.

FIG 3

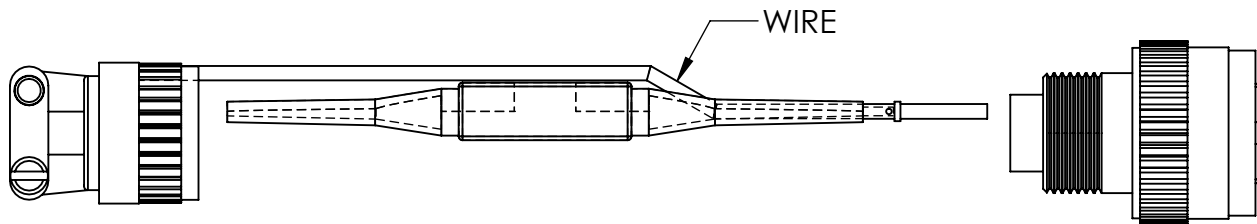

SLIDE CONTACT AND WIRE THROUGH CLAMP. THEN SLIDE CONTACT AND WIRE INTO RED END OF INSERTION TOOL. BEGINNING FROM THE CENTER CAVITY AND WORKING OUTWARDS IN A CIRCULAR PATTERN, INSERT WIRED CONTACTS INTO PLUG. PUSH TOOL STRAIGHT INTO CAVITY UNTIL CONTACT SNAPS INTO POSITION. A LIGHT PULL ON THE WIRE WILL ASSURE THAT THE CONTACT IS SECURELY IN POSITION. REMOVE INSERTION TOOL AND REPEAT.

APPLIES TO:	
No. OF PINS	PLUG P/N
3	KT18063
6	KT18065
10	KT14378
19	KT14379
32	KT14380
41	KT14381

PROPRIETARY AND CONFIDENTIAL

THE INFORMATION CONTAINED IN THIS DRAWING IS THE SOLE PROPERTY OF SOLID SEALING TECHNOLOGY. ANY REPRODUCTION IN PART OR AS A WHOLE WITHOUT THE WRITTEN PERMISSION OF SOLID SEALING TECHNOLOGY IS PROHIBITED.

THIRD ANGLE PROJECTION

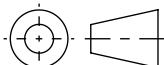

TITLE:

INSTRUCTION SHEET  
26482 PLUG ASSEMBLY



**SOLID SEALING**  
TECHNOLOGY

REV.	APP'D	DATE	SCALE 1:1	DIMENSIONS IN INCHES [mm]	DRAWN	JS	9/11/2008	NUMBER:
C	JF	01/31/2025	NS18065-11		ENG APPR.	OG	12/05/2008	

NS18065

REV: C

SHEET 1 OF 1