

## ASSEMBLY INSTRUCTIONS FOR PLUG FA19648

### ASSEMBLY INSTRUCTIONS:

- 1- INSERT WIRES THROUGH CONTACT RETAINER AND CRIMP TO CONTACTS. USE CRIMP TOOL FP13347 (SEE TABLE FOR SETTING).
- 2- AFTER CRIMPING SEAT CONTACTS INTO PLUG. SEE TABLE BELOW FOR CONTACT LOCATIONS.
- 3- INSERT CONTACT RETAINER INTO PLUG
- 4- INSERT RETAINING RING INTO GROOVE IN BACK OF PLUG.

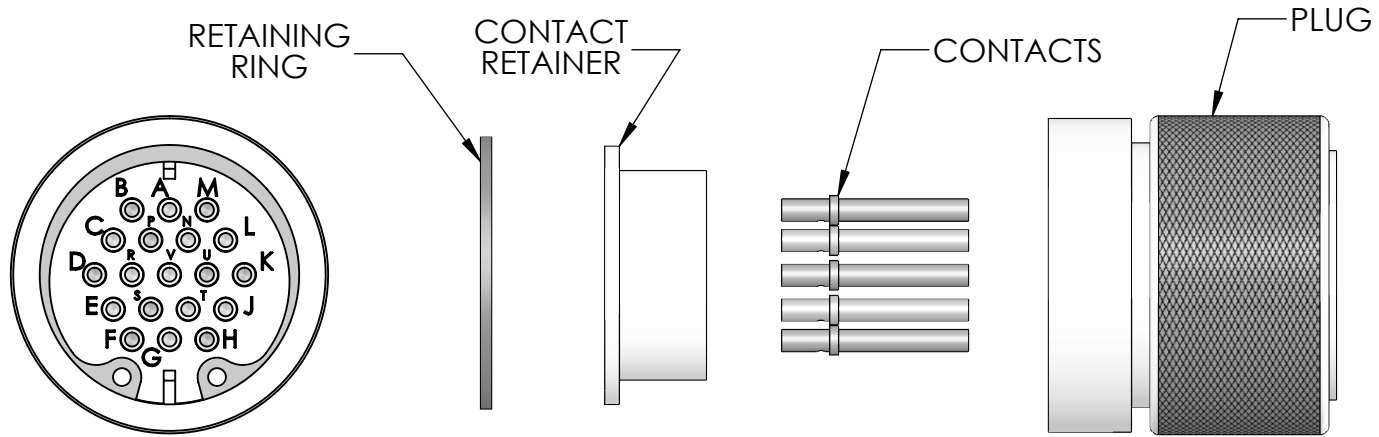

(+) CHROMEL CONTACT P/N CP13353-02 LOCATIONS	(-) ALUMEL CONTACT P/N CP13353-03 LOCATIONS
A,C,E,G,J,L,N,R,T,V	B,D,F,H,K,M,P,S,U

CONTACT IDENTIFICATION	
MATERIAL:	COLOR BANDS:
CHROMEL	BROWN-YELLOW-BROWN
ALUMEL	BROWN-YELLOW-BLACK

FP13347 CRIMP TOOL SETTING	
WIRE AWG	TOOL SETTING
20	4
22	3
24	2

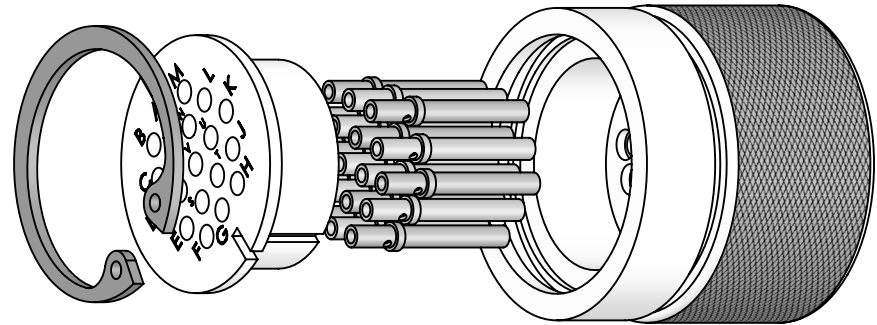

PROPRIETARY AND CONFIDENTIAL  
THE INFORMATION CONTAINED IN THIS DRAWING IS THE SOLE PROPERTY OF SOLID SEALING TECHNOLOGY. ANY REPRODUCTION IN PART OR AS A WHOLE WITHOUT THE WRITTEN PERMISSION OF SOLID SEALING TECHNOLOGY IS PROHIBITED.

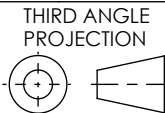

TITLE  
**INSTRUCTION SHEET  
T/C TYPE K PLUG ASSEMBLY**



REV.	APP'D	DATE	SCALE 3:2	DIMENSIONS IN INCHES [mm]	DRAWN	CW	10/5/2020	NUMBER	NS19648	REV	A	SHEET 1 OF 1
A	JF	06/10/2021	MSME0006-12EX		ENG APPR.	JF	06/10/2021					