

## ASSEMBLY INSTRUCTIONS FOR PLUG FA19648

### ASSEMBLY INSTRUCTIONS:

- 1- INSERT WIRES THROUGH CONTACT RETAINER AND CRIMP TO CONTACTS. USE CRIMP TOOL SST P/N FP44440 AND LOCATOR SST P/N FP44441.
- 2- AFTER CRIMPING SEAT CONTACTS INTO PLUG. SEE TABLE BELOW FOR CONTACT LOCATIONS.
- 3- INSERT CONTACT RETAINER INTO PLUG
- 4- INSERT RETAINING RING INTO GROOVE IN BACK OF PLUG.

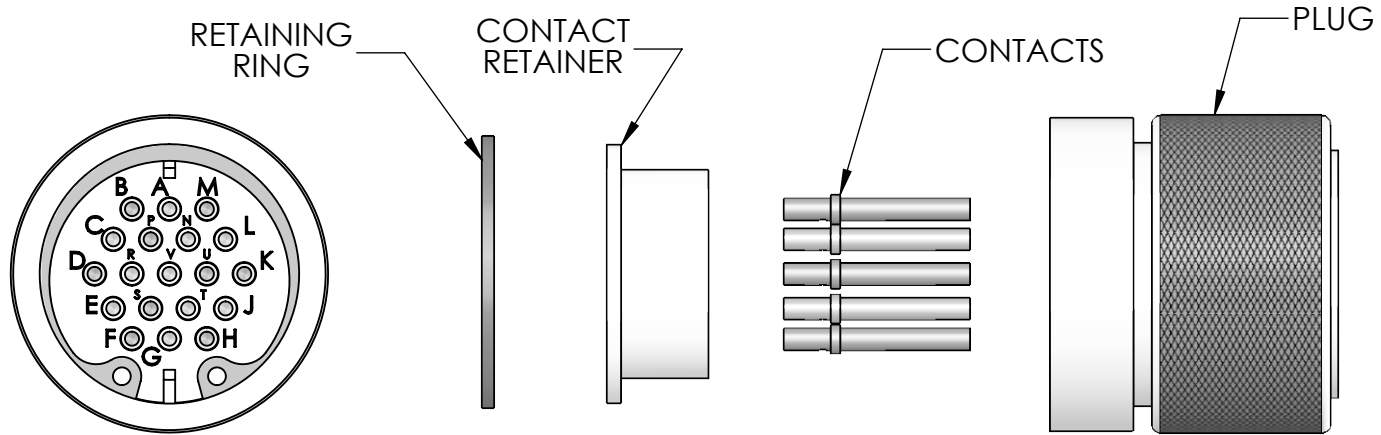

(+) CHROMEL CONTACT P/N CP13353-02 LOCATIONS A,C,E,G,J,L,N,R,T,V	(-) ALUMEL CONTACT P/N CP13353-03 LOCATIONS B,D,F,H,K,M,P,S,U
--	---

CONTACT IDENTIFICATION	
MATERIAL:	COLOR BANDS:
CHROMEL	BROWN-YELLOW-BROWN
ALUMEL	BROWN-YELLOW-BLACK

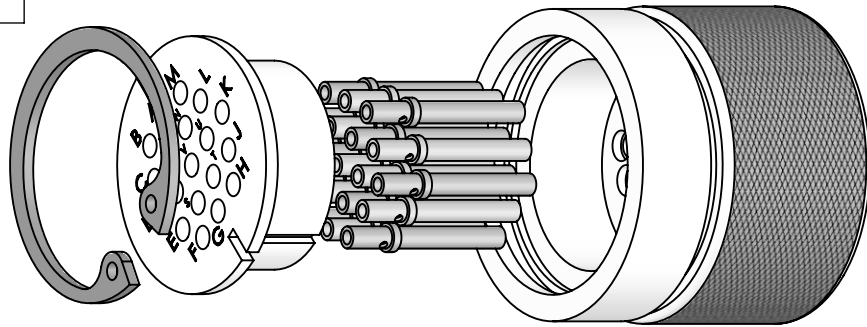

PROPRIETARY AND CONFIDENTIAL THE INFORMATION CONTAINED IN THIS DRAWING IS THE SOLE PROPERTY OF SOLID SEALING TECHNOLOGY. ANY REPRODUCTION IN PART OR AS A WHOLE WITHOUT THE WRITTEN PERMISSION OF SOLID SEALING TECHNOLOGY IS PROHIBITED.				THIRD ANGLE PROJECTION 		TITLE <b>INSTRUCTION SHEET                  T/C TYPE K PLUG ASSEMBLY</b>				
REV.	APP'D	DATE	SCALE 3:2	DIMENSIONS IN INCHES [mm]	DRAWN	CW	10/5/2020	NUMBER	REV	
B	JF	02/04/2025	MSME0006-12EX		ENG APPR.	JF	06/10/2021	NS19648	B	
								SHEET 1 OF 1		