

**THIS INSTRUCTION SHEET APPLIES TO PLUGS: KT19712, KT14134, KT19713 & KT24173**

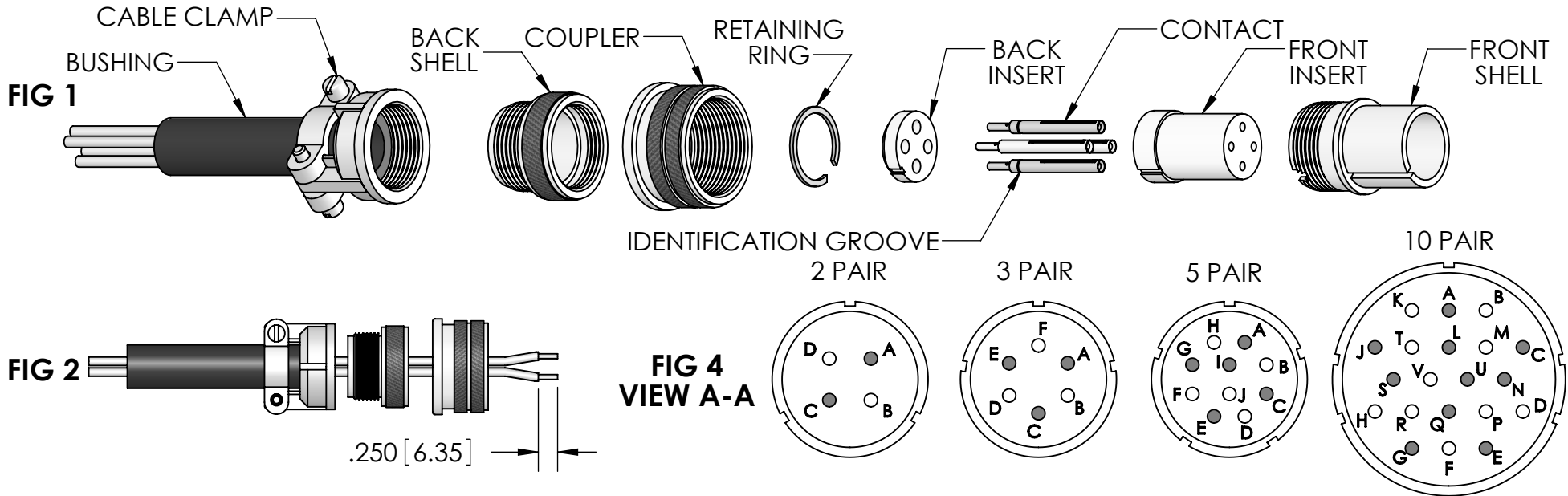

SLIDE CABLE CLAMP, BUSHING, BACK SHELL, AND COUPLER OVER WIRES. STRIP EACH CONDUCTOR TO DIMENSION SHOWN ABOVE.

SHADED CIRCLES INDICATE PLACEMENT OF POSITIVE (+) CHROMEL THERMOCOUPLE LEADS (CHROMEL CONTACTS MARKED WITH IDENTIFICATION GROOVE) AND UNSHADED CIRCLES INDICATE PLACEMENT OF NEGATIVE (-) ALUMEL THERMOCOUPLE LEADS.

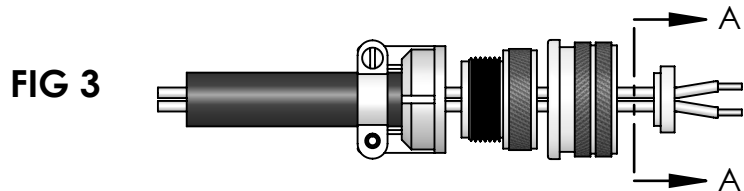

INSERT THE PROPER THERMOCOUPLE MATERIAL INTO THE HOLES IN THE BACK INSERT. (SEE "FIG 4" FOR HOLE IDENTIFICATION.)

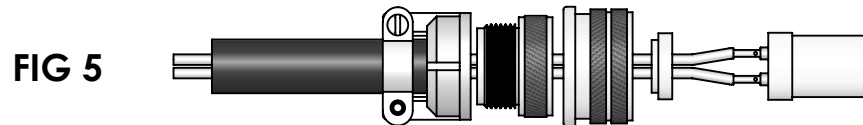

SLIDE THE PROPER CONTACT ONTO THE CORRESPONDING CONDUCTOR AND CRIMP INTO PLACE (SEE PAGE 2 FOR CRIMP SETTINGS OF CRIMP TOOL FP13347). INSERT CONTACTS INTO THE PROPER HOLES IN THE FRONT INSERT. ALIGNMENT SLOTS AND LETTERS ON FRONT AND BACK INSERTS SHOULD BE IN LINE.

PROPRIETARY AND CONFIDENTIAL

THE INFORMATION CONTAINED IN THIS DRAWING IS THE SOLE PROPERTY OF SOLID SEALING TECHNOLOGY. ANY REPRODUCTION IN PART OR AS A WHOLE WITHOUT THE WRITTEN PERMISSION OF SOLID SEALING TECHNOLOGY IS PROHIBITED.

THIRD ANGLE PROJECTION

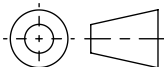

TITLE:

**INSTRUCTION SHEET  
5015 T/C PLUG ASSEMBLY**



**SOLID SEALING  
TECHNOLOGY**

REV.	APP'D	DATE	SCALE 1:2	DIMENSIONS IN INCHES [mm]	DRAWN	MH	12/15/2008	NUMBER:
D	JF	06/10/2021	NS19712-11		ENG APPR.	MH	12/15/2008	

**NS19712**

REV: **D**

SHEET 1 OF 2

**FIG 6**

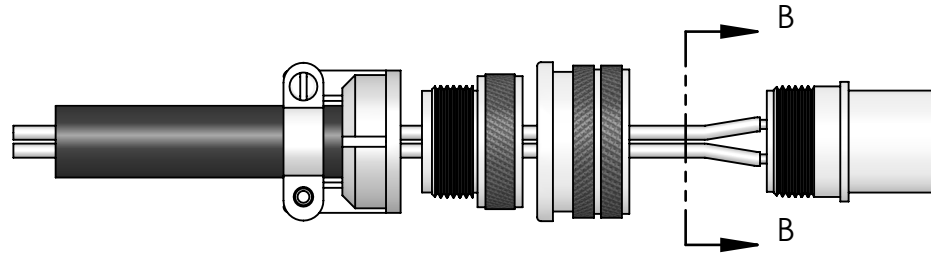

SLIDE THE FRONT AND BACK INSERTS TOGETHER AND INSERT THEM INTO THE FRONT SHELL. MAKE SURE TO ALIGN INSERT LETTERS AND SLOT TO FRONT SHELL SLOT AS SHOWN IN "FIG 7". SECURE THEM IN PLACE BY INSERTING THE RETAINING RING.

**FIG 7  
VIEW B-B**

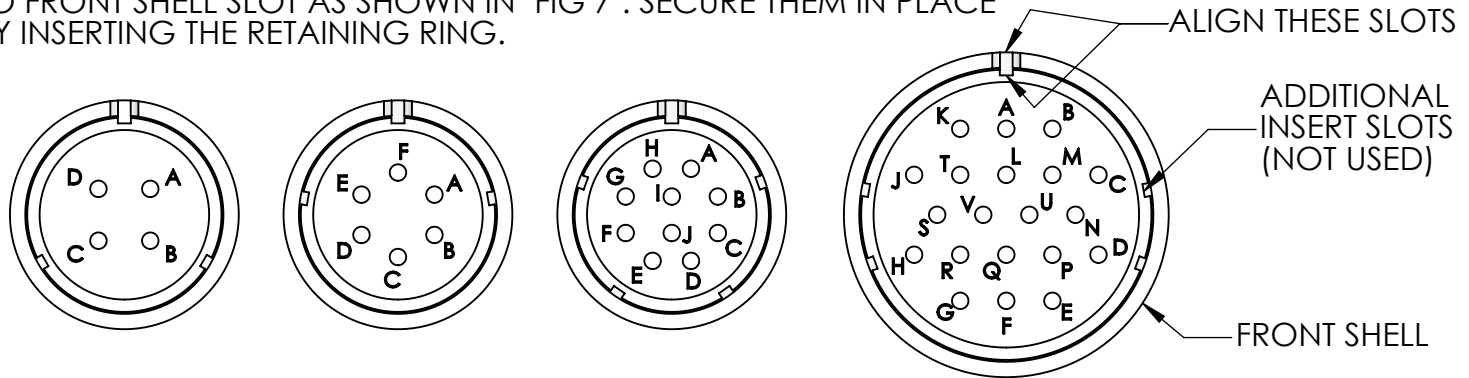
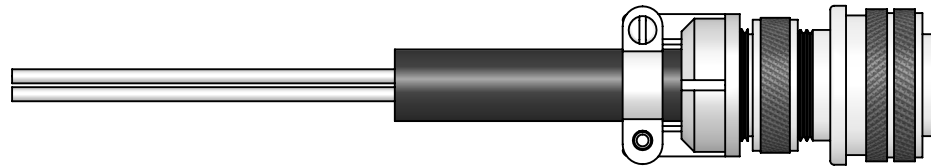

FIGURE ABOVE SHOWS CORRECT ALIGNMENT OF INSERT LETTERS AND SLOT TO FRONT SHELL SLOT.

**FIG 8**



SLIDE COUPLER OVER FRONT SHELL. THREAD BACK SHELL ONTO FRONT SHELL AND TIGHTEN. THREAD CABLE CLAMP ONTO THE BACK SHELL AND TIGHTEN. MODERATELY TIGHTEN CABLE CLAMP SCREWS TO PROVIDE ADEQUATE STRAIN RELIEF TO WIRES AND CONTACTS.

FP13347 CRIMP TOOL SETTING	
WIRE AWG	TOOL SETTING
20	4
22	3
24	2

PROPRIETARY AND CONFIDENTIAL  
THE INFORMATION CONTAINED IN THIS DRAWING IS THE SOLE PROPERTY OF SOLID SEALING TECHNOLOGY. ANY REPRODUCTION IN PART OR AS A WHOLE WITHOUT THE WRITTEN PERMISSION OF SOLID SEALING TECHNOLOGY IS PROHIBITED.

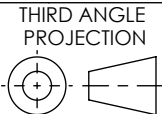

TITLE: **INSTRUCTION SHEET**  
**5015 T/C PLUG ASSEMBLY**



REV.	APP'D	DATE	SCALE 1:2	DIMENSIONS IN INCHES [mm]	DRAWN	MH	12/15/2008	NUMBER:
D	JF	06/10/2021	NS19712-15		ENG APPR.	MH	12/15/2008	NS19712

REV: **D** SHEET 2 OF 2