

THIS INSTRUCTION SHEET APPLIES TO PLUG FA39111.

### 3 PIN POWER D VACUUM SIDE PLUG TO WIRE ASSEMBLY

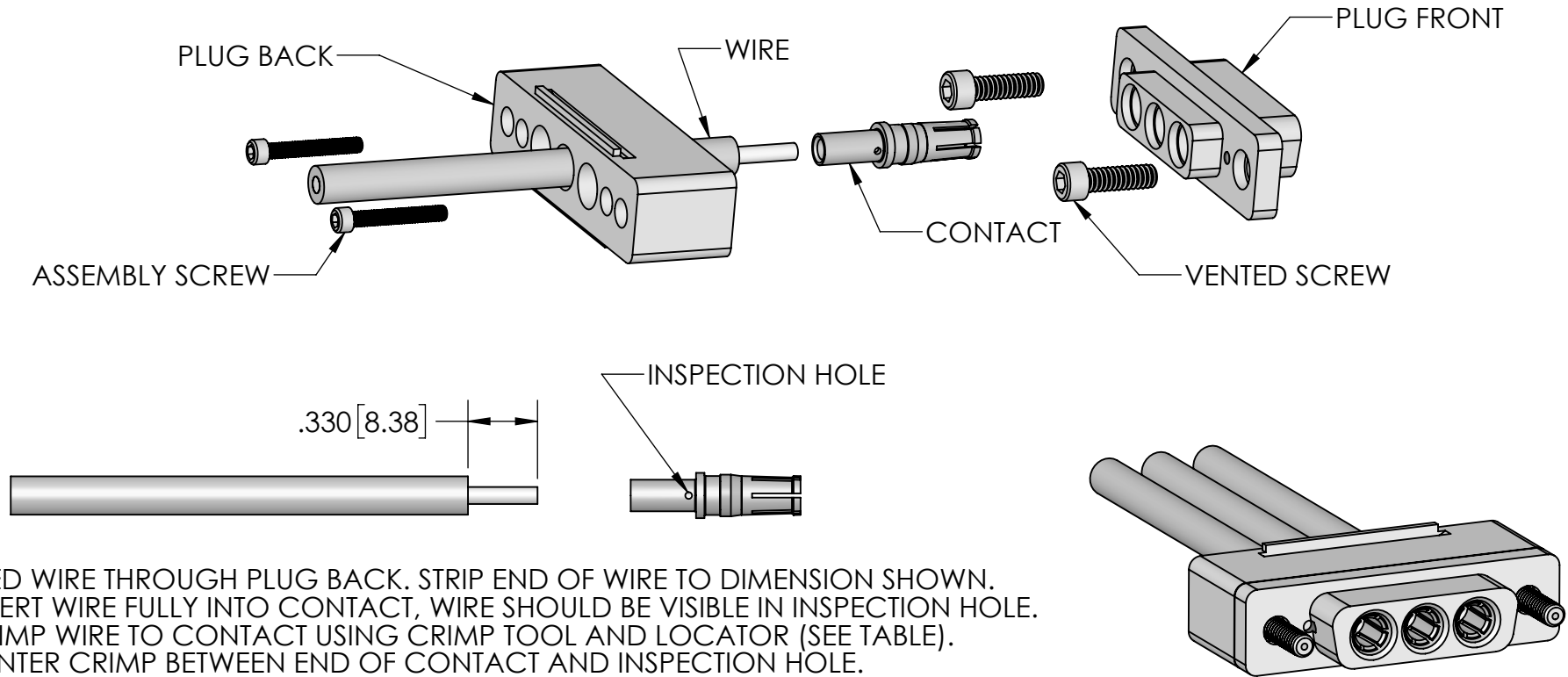

FEED WIRE THROUGH PLUG BACK. STRIP END OF WIRE TO DIMENSION SHOWN. INSERT WIRE FULLY INTO CONTACT, WIRE SHOULD BE VISIBLE IN INSPECTION HOLE. CRIMP WIRE TO CONTACT USING CRIMP TOOL AND LOCATOR (SEE TABLE). CENTER CRIMP BETWEEN END OF CONTACT AND INSPECTION HOLE.

INSERT VENTED SCREWS INTO COUNTERBORES IN PLUG FRONT. THEN INSERT CONTACTS INTO PLUG FRONT HOLES. ALIGN PLUG BACK AND PLUG FRONT. INSERT ASSEMBLY SCREWS IN PLUG BACK AND TIGHTEN.

PLUG FA39111 MAY BE USED WITH CRIMP CONTACTS FP39118 OR FP39118-02

CONTACT P/N	CONTACT CURRENT RATING	WIRE SIZE AWG	CRIMP TOOL (SETTING)	CRIMP LOCATOR P/N (COLOR)
FP39118	20 AMPS	12	FP39756 (1)	FP39764 (N/A)
FP39118-02	10 AMPS	16	FP42785 (6)	FP42786 (RED)

PROPRIETARY AND CONFIDENTIAL THE INFORMATION CONTAINED IN THIS DRAWING IS THE SOLE PROPERTY OF SOLID SEALING TECHNOLOGY. ANY REPRODUCTION IN PART OR AS A WHOLE WITHOUT THE WRITTEN PERMISSION OF SOLID SEALING TECHNOLOGY IS PROHIBITED.				THIRD ANGLE PROJECTION 		TITLE: INSTRUCTION SHEET SUB-D POWER VACUUM PLUG			
REV. A1	APP'D JF	DATE 07/02/2021	SCALE 1.25:1	DIMENSIONS IN INCHES [mm]	DRAWN ENG APPR. JF	CW	6/30/2021	NUMBER: NS39111	REV: A1
								SHEET 1 OF 1	