

THIS INSTRUCTION SHEET APPLIES TO PLUG FA41232 USED WITH CONTACTS KT41236 OR KT41236-02.

ASSEMBLY INSTRUCTIONS:

- 1- STRIP WIRE INSULATION TO EXPOSE .060-.090" [1.53-2.28 mm] OF WIRE CORE. INSERT STRIPPED WIRES THROUGH SKID WASHER AND REAR INSERT. CRIMP WIRE TO CONTACTS. CRIMP USING FP41735 CRIMP TOOL (CRIMP SETTING 5) WITH FP41731 LOCATOR.
- 2- AFTER CRIMPING SEAT CONTACTS INTO REAR INSERT.
- 3- INSERT REAR INSERT INTO FRONT INSERT MAKING SURE THE CONTACTS HAVE FULLY SEATED INTO THE FRONT INSERT. THIS IS VISUALLY CONFIRMED WHEN THE SHOULDERS ON BOTH INSERTS ARE NEARLY TOUCHING.
- 4- INSTALL INSERT ASSEMBLY INTO COUPLING NUT, THEN INSTALL SKID WASHER AND RETAINING RING INSIDE COUPLING NUT.
- 5- CONTACTS ACCEPT A 28-32 AWG WIRE SIZE FOR CRIMP.
- 6- MAXIMUM WIRE INSULATION OD: .030" [0.76 mm]

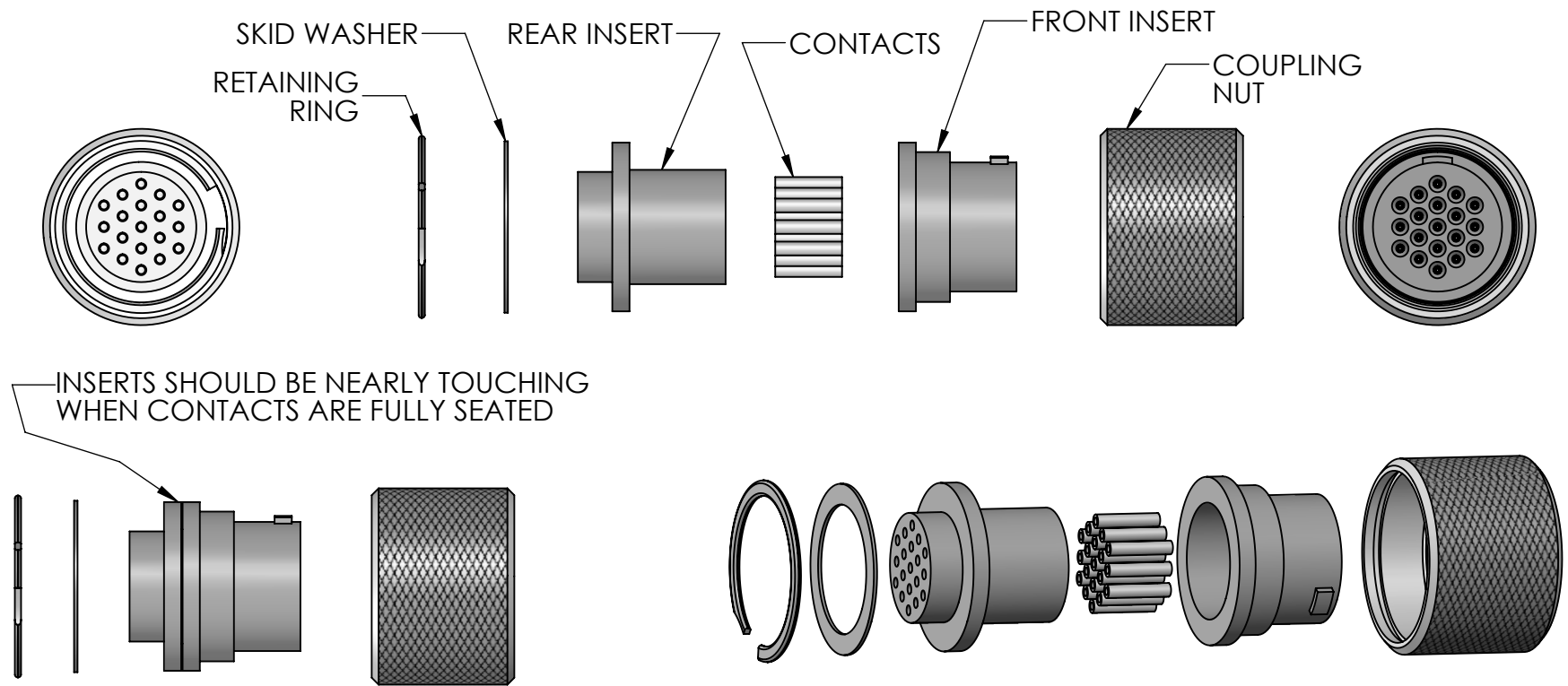

| | | | | | | | | | | | | |
|--|-------|------------|---------------|----------------------------|-----------|---|------------|---------|---------|------|---|--------------|
| PROPRIETARY AND CONFIDENTIAL THE INFORMATION CONTAINED IN THIS DRAWING IS THE SOLE PROPERTY OF SOLID SEALING TECHNOLOGY. ANY REPRODUCTION IN PART OR AS A WHOLE WITHOUT THE WRITTEN PERMISSION OF SOLID SEALING TECHNOLOGY IS PROHIBITED. | | | | THIRD ANGLE PROJECTION | | TITLE: INSTRUCTION SHEET MICRO C PLUG ASSEMBLY | | | | | | |
| REV. | APP'D | DATE | SCALE 2:1 | DIMENSIONS IN INCHES [mm] | DRAWN | HJ | 9/17/2020 | NUMBER: | NS41232 | REV: | B | SHEET 1 OF 1 |
| B | JF | 04/21/2021 | MSPLR004-19WS | | ENG APPR. | HJ | 12/10/2020 | | | | | |