

THIS INSTRUCTION SHEET APPLIES TO MICRO C RECEPTACLES FA42367, FA41656, & FA42375.

**ASSEMBLY INSTRUCTIONS:**

- 1- INSERT WIRES THROUGH REAR INSERT AND STRIP .060-.090" [1.53-2.28 mm] OF INSULATION FROM WIRES. CRIMP USING FP41735 CRIMP TOOL (CRIMP SETTING 5) WITH FP41731 LOCATOR.
- 2- AFTER CRIMPING SEAT CONTACTS INTO REAR HOUSING AND INSTALL REAR INSERT INTO BORE IN BACK OF HOUSING.
- 3- INSTALL RETAINING RING IN GROOVE BEHIND REAR INSERT.

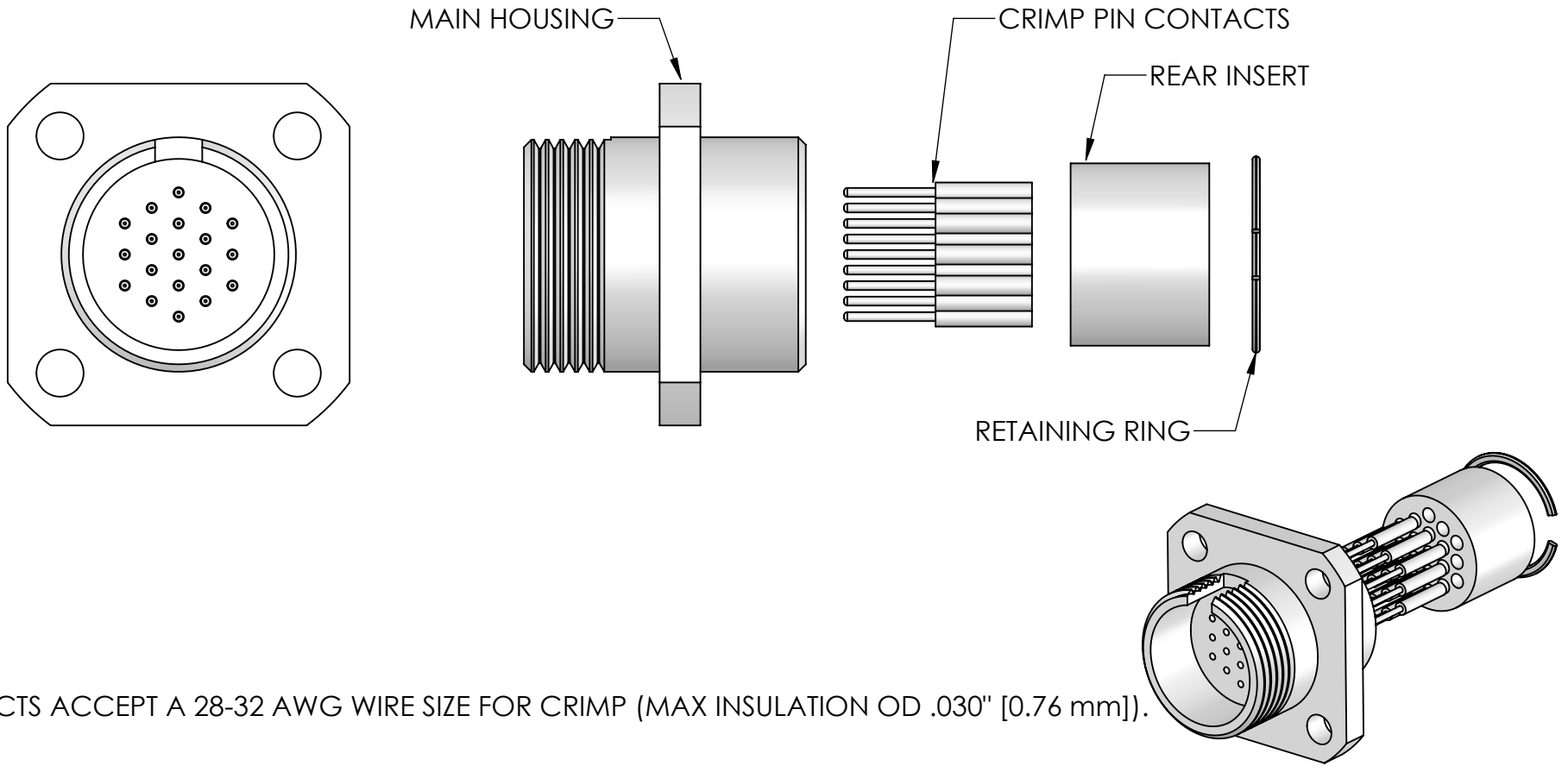

CONTACTS ACCEPT A 28-32 AWG WIRE SIZE FOR CRIMP (MAX INSULATION OD .030" [0.76 mm]).

FA41656 SHOWN

PROPRIETARY AND CONFIDENTIAL THE INFORMATION CONTAINED IN THIS DRAWING IS THE SOLE PROPERTY OF SOLID SEALING TECHNOLOGY. ANY REPRODUCTION IN PART OR AS A WHOLE WITHOUT THE WRITTEN PERMISSION OF SOLID SEALING TECHNOLOGY IS PROHIBITED.				THIRD ANGLE PROJECTION 		TITLE: INSTRUCTION SHEET MICRO C RECEPTACLE			
REV.	APP'D	DATE	SCALE 3:1	DIMENSIONS IN INCHES [mm]	DRAWN	HJ	11/9/2020	NUMBER:	NS41656
A	HJ	03/18/2021	MSRC0001-11		ENG APPR.	HJ	03/18/2021	REV: A	
								SHEET 1 OF 1	