

THIS INSTRUCTION SHEET APPLIES TO PLUG FA42137 USED WITH CONTACTS KT41236 OR KT41236-02.

**ASSEMBLY INSTRUCTIONS:**

- 1- REAR BODY, GARTER SPRING, AND CAPTIVE SOCKET CAP SCREWS TO BE PRE-ASSEMBLED BEFORE SHIPMENT FROM SST.
- 2- FEED WIRE THROUGH REAR BODY. STRIP WIRE INSULATION TO EXPOSE .060-.090" [1.53-2.28 mm] OF WIRE CORE. INSERT WIRE FULLY INTO CONTACT. CRIMP WIRE TO CONTACT USING FP41735 CRIMP TOOL (CRIMP SETTING 5) WITH FP41731 LOCATOR.
- 3- AFTER CRIMPING SEAT CONTACTS INTO FRONT BODY AND SEAT REAR BODY INTO FRONT BODY, SNAPPING GARTER SPRING INTO GROOVES ON FRONT BODY (THIS HOLDS PLUG TOGETHER WHEN UNMATED).

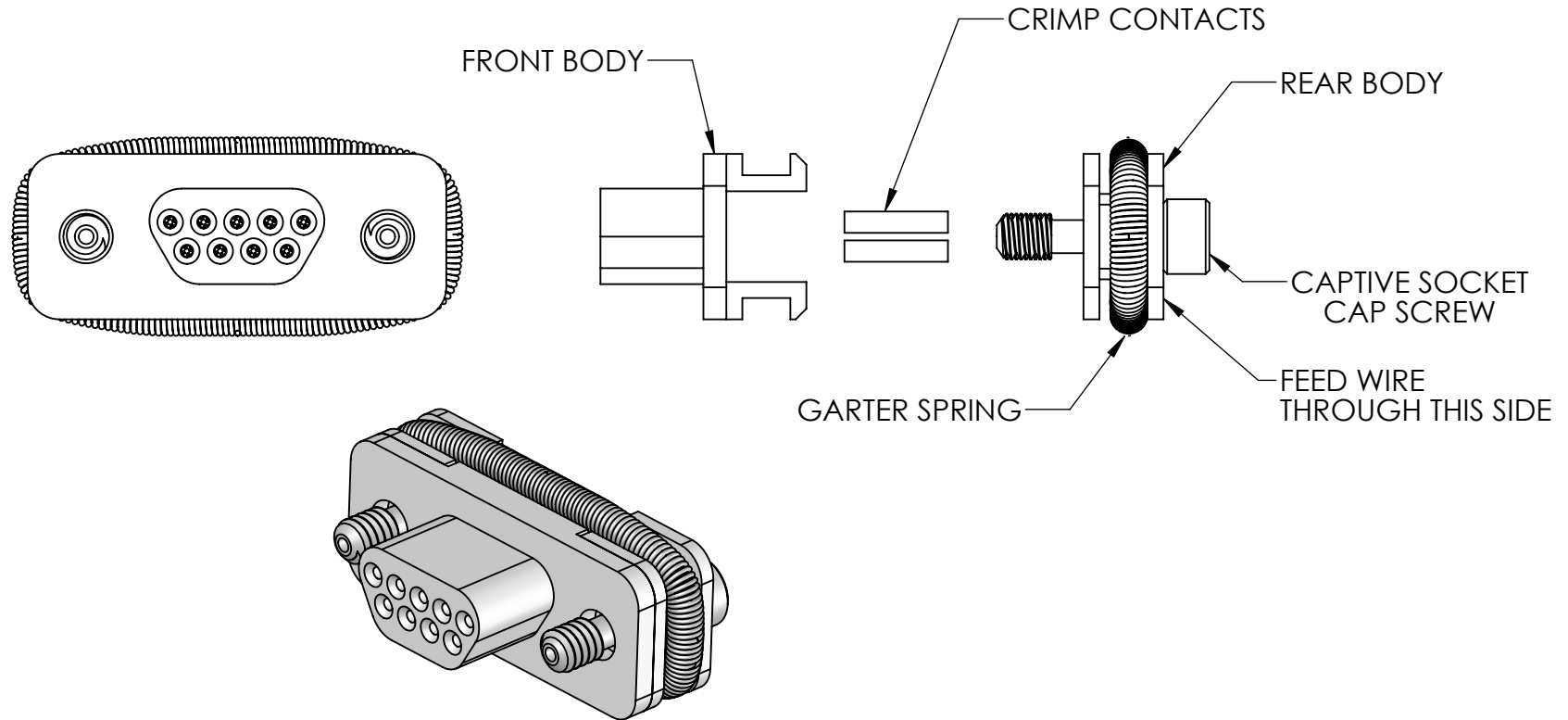

CONTACTS ACCEPT A 28-32 AWG WIRE SIZE FOR CRIMP (MAX INSULATION OD .030" [0.76 mm]).

PROPRIETARY AND CONFIDENTIAL THE INFORMATION CONTAINED IN THIS DRAWING IS THE SOLE PROPERTY OF SOLID SEALING TECHNOLOGY. ANY REPRODUCTION IN PART OR AS A WHOLE WITHOUT THE WRITTEN PERMISSION OF SOLID SEALING TECHNOLOGY IS PROHIBITED.				THIRD ANGLE PROJECTION 		TITLE: INSTRUCTION SHEET MICRO D+ PLUG ASSEMBLY						
REV.	APP'D	DATE	SCALE 3:1	DIMENSIONS IN INCHES [mm]	DRAWN	CW	4/21/2021	NUMBER:	NS42137	REV:	A	SHEET 1 OF 1
A	JF	04/22/2021	LR006-11 WITH SOCKET		ENG APPR.	JF	04/22/2021					