

NOTES

- 1- SAFETY GLASSES AND PROTECTIVE GLOVES MUST BE WORN ANY TIME PINCH OFF TOOL IS OPERATED.
- 2- ENSURE THAT BOTH DIES ARE PLACED CORRECTLY IN THE TOOL, THE MARKING ARBOR AND PISTON SHOULD BE VISIBLE ON THEIR RESPECTIVE DIES.
- 3- CLOSE RELEASE KNOB
- 4- PLACE TUBE BETWEEN THE DIES (SEE FIGURE 1)
- 5- PUMP HANDLE TO CLOSE GAP BETWEEN DIES, (SEE DETAIL A)
- 6- ONCE DIES TOUCH, TUBE SHOULD FREELY SEPARATE INTO 2 PICES.  
IF TUBE DOES NOT SEPARATE RELEASE PISTON, REMOVE TOOL AND GENTLY FLEX PINCHED AREA TO FULLY SEPERATE.
- DO NOT OVER PUMP DIES ARE HARDENED AND MAY FRACTURE**
- 7- LOOSEN RELEASE KNOB TO RESET .

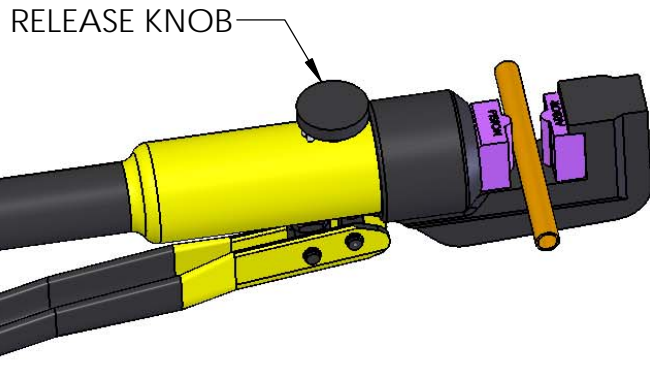
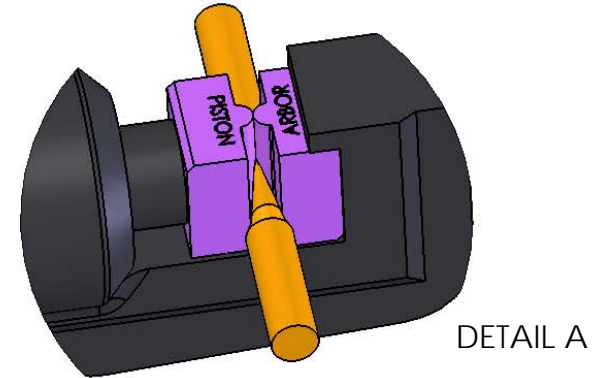
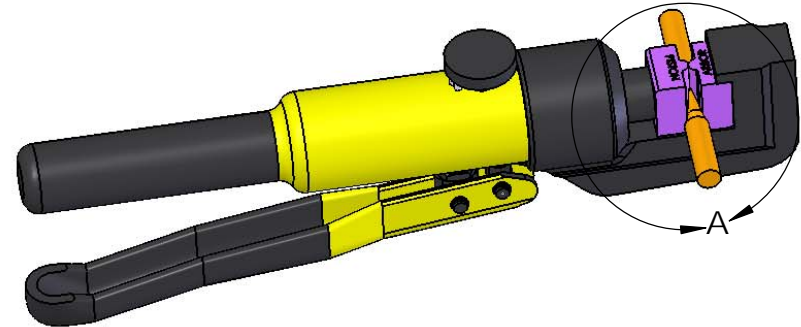

FIGURE 1



PROPRIETARY AND CONFIDENTIAL

THE INFORMATION CONTAINED IN THIS DRAWING IS THE SOLE PROPERTY OF SOLID SEALING TECHNOLOGY. ANY REPRODUCTION IN PART OR AS A WHOLE WITHOUT THE WRITTEN PERMISSION OF SOLID SEALING TECHNOLOGY IS PROHIBITED.

THIRD ANGLE PROJECTION

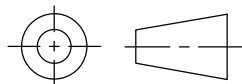

TITLE: INSTRUCTION SHEET  
PINCH OFF TUBE INSTRUCTIONS



REV.	APP'D	DATE	SCALE 1:3	DIMENSIONS IN INCHES [mm]	DRAWN	MH	2/13/2017
A	MH	2/13/2017	MSME0079-11		ENG APPR.	MH	2/13/2017

NUMBER:	NS35046
---------	---------

REV:	A
------	---