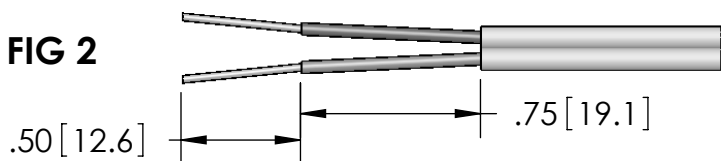

FIG 1

T/C TYPE	T/C (+) MATERIAL	T/C (-) MATERIAL	PLUG OR DOT COLOR
K	CHROMEL	ALUMEL	YELLOW
J	IRON	CONSTANTAN	BLACK
C	TUNGSTEN 5% RHENIUM	TUNGSTEN 26% RHENIUM	RED
E	CHROMEL	CONSTANTAN	PURPLE

REMOVE PLUG COVER BY LOOSENING SCREWS.

FIG 2



.50 [12.6]

.75 [19.1]

CUT AND STRIP THERMOCOUPLE WIRE JACKET AND DIELECTRIC TO DIMENSIONS SHOWN ABOVE. PLUG ACCEPTS STRANDED OR SOLID WIRE UP TO SIZE 20 AWG.

FIG 4

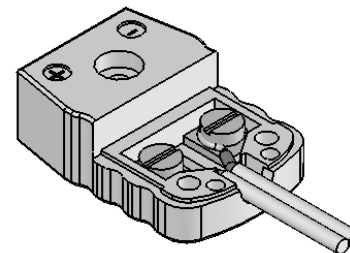

HOOK CONDUCTORS UNDER CONTACT SCREW HEADS AND TIGHTEN MODERATELY.

FIG 3

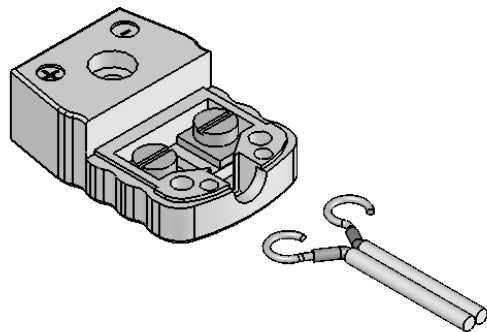

LOOP CONDUCTORS IN A CLOCKWISE DIRECTION AS SHOWN TO FIT AROUND A ϕ .096 CONTACT SCREW. LOOSEN CONTACT SCREWS ABOUT 3 TURNS TO ALLOW CONDUCTORS TO BE FASTENED UNDER SCREW HEADS.

FIG 5

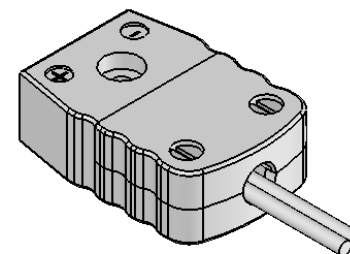

PLACE COVER BACK ON PLUG AND TIGHTEN SCREWS MODERATELY. BE CAREFUL NOT TO STRIP THE THREADS IN THE COVER.

PROPRIETARY AND CONFIDENTIAL

THE INFORMATION CONTAINED IN THIS DRAWING IS THE SOLE PROPERTY OF SOLID SEALING TECHNOLOGY. ANY REPRODUCTION IN PART OR AS A WHOLE WITHOUT THE WRITTEN PERMISSION OF SOLID SEALING TECHNOLOGY IS PROHIBITED.

THIRD ANGLE PROJECTION

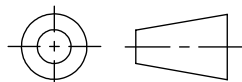

TITLE: INSTRUCTION SHEET
SPADE PLUG ASSEMBLY



SOLID SEALING TECHNOLOGY, INC.

REV.	APP'D	DATE	SCALE 5:4	DIMENSIONS IN INCHES [mm]	DRAWN	JS	10/28/2008
A	MH	11/03/2008	TC WIRE-11		ENG APPR.	MH	11/03/2008

NUMBER: NS11728

REV: A

SHEET 1 OF 1